



تله بخار ترمودینامیکی

Thermodynamic Steam Trap With Bimetallic Air Vent

TD 62-(F, T, S)

General Specification:

Steam traps are used to remove condensate from steam lines. This type of trap is applied for high pressures, and has such capacity to get repaired without separating from the pipeline. It is equipped with a bimetal ring to drain excess air in the system. It has a high discharge capacity due to its low weight and volume, and also the ability to be installed in different directions. Moreover, it has good resistance against the frost and water hammer.

مشخصات کلی:

تله بخار ها جهت خارج کردن کندانس از خطوط بخار مورد استفاده قرار می گیرند. این نوع تراب جهت فشارهای بالا استفاده می شود و قابلیت آن را دارد تا بدون جدا کردن از خط لوله تعمیر و یا سرویس گردد. مجهز به یک رینگ بيمتال می باشد تا هوای اضافی موجود در سیستم را تخلیه نماید. دارای ظرفیت تخلیه بالا با توجه به حجم و وزن پایین خود می باشد. دارای قابلیت نصب در جهات مختلف می باشد. مقاومت خوبی در برابر یخ زدگی و ضربه های قوچ دارد.

Technical information

Body Material	A105	A182 F321	
Connection	Threaded	S.Welded	Flanged
Size	DN15.20.25 - ½", ¾", 1"		
Maximum Operating Pressure (bar)	65		
Minimum Operating Pressure (bar)	0.3		
Maximum Operating Temperature (°C)	425		
Maximum Allowable Pressure(bar)	107 @ 40 °C	116 @ 40 °C	
Maximum Allowable Temperature (°C)	425 @ 65 bar	550 @ 60 bar	
Maximum Back Pressure	80% of Inlet Pressure		

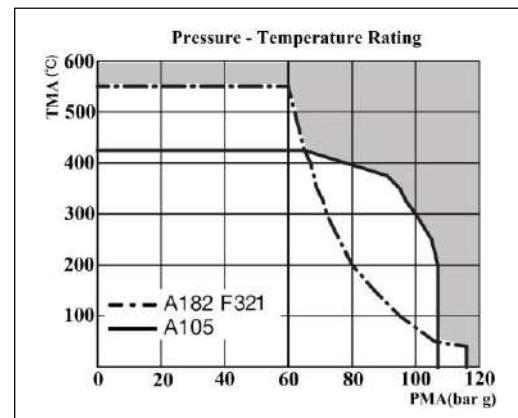

Notice: The operating conditions shall be in such way that operation of trap does not enter the shaded part.

Components, assembly drawing and Material

No.	Description	Material	ASTM/AISI
1	Nameplate	Stainless Steel	AISI304
2	Cover	Stainless Steel	AISI304
3	Cap	Stainless Steel	AISI420
4	Disc	Stainless Steel	AISI440C
5	Disc Holder Ring	Stainless Steel	AISI630/420
6	Air Vent Ring	Bimetal	Bimetal
7	Module Valve Seat	Stainless Steel	AISI440C
8	Body	Carbon Steel / Stainless Steel	A105/A182F321
9	Strainer	Stainless Steel	AISI316L
10	Screen Holder	Stainless Steel	A351 Gr.CF8

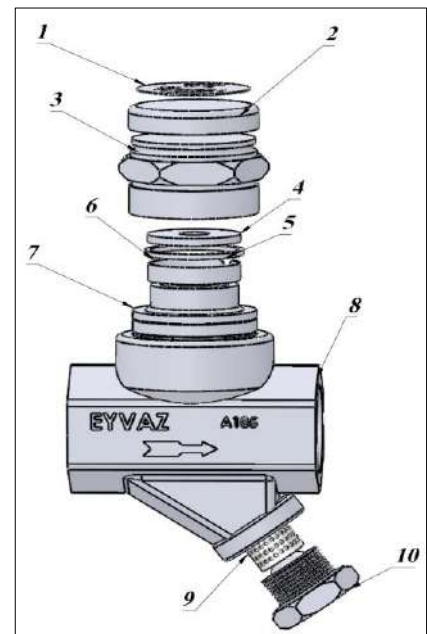

• TD62 Threaded-Socket Welded

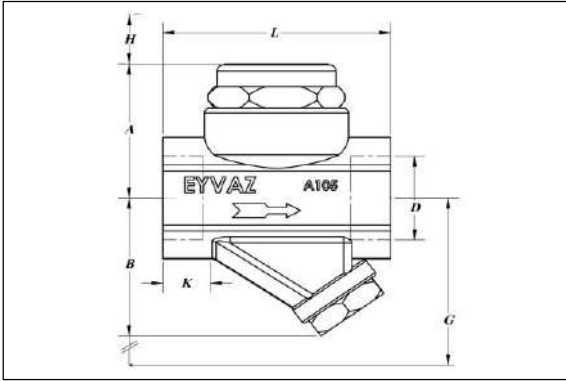

Size	L	K	D	G	H	A	B	Weight (kg)
15-1/2"	80	13	22.2	30	30	58	62	1.2
20-3/4"			27.7					1.2
25-1"	88	14	34.5			63		1.4

G: The minimum space needed to assemble a strainer

H: The minimum space needed to assemble a cap

• TD62 Flanged

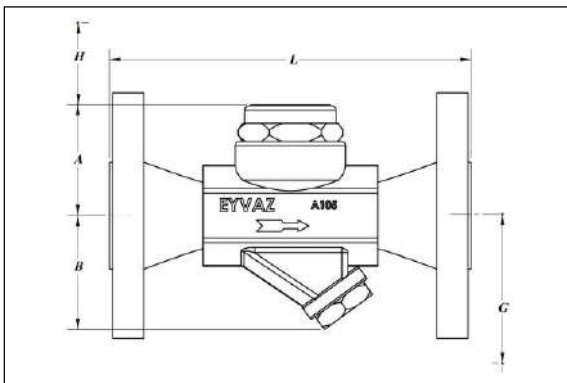

Size	L(Class RF)				G	H	A	B	Weight* (kg)
	150	300	600	900					
15-1/2"	150	150	150	160	30	30	58	62	5.7
20-3/4"	165	165	165	190					7.1
25-1"	180	180	180	200			63		10

*Weight is for class 900RF

Discharge Capacity

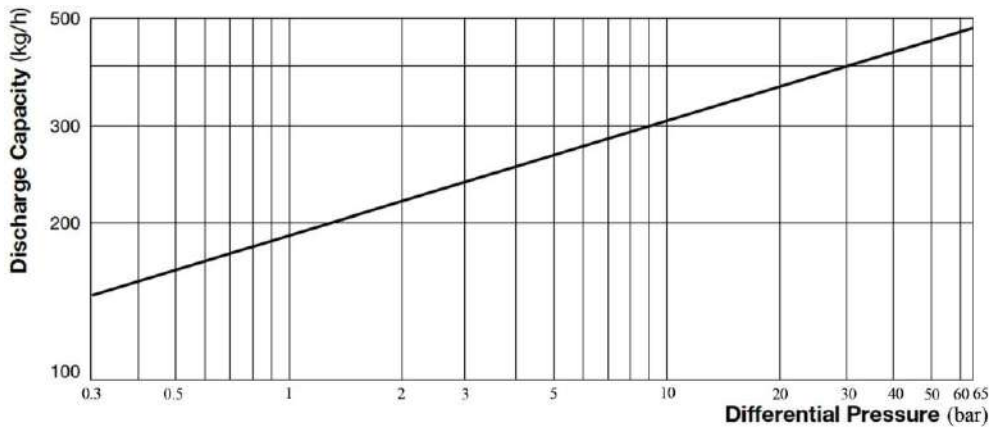

Differential pressure is the difference between the inlet and outlet pressure of the trap.

Installation

Thermodynamic Traps can be installed in two ways including vertical and horizontal. The flow direction within the traps shall be in accordance with the arrow on the body.